

Hydro Stator End Winding Accelerometer System

Bently Nevada™ Asset Condition Monitoring

Description

The hydro Stator End Winding Accelerometer (SEW Accel) system provides a cost effective and reliable method for monitoring Stator End Winding vibration. This product utilizes a dual axis MEMS capacitive accelerometer encapsulated in a highly electrically insulated probe housing and mounting system. This unique sensor system provides flexibility and simplicity of installation. The hydro SEW Accel system is safe, reliable and durable for hydro applications.

The hydro SEW Accel system consists of two major components (Sold Separately):

- 330446 Accelerometer Sensor
- 330447 Accelerometer Probe

The Bently Nevada hydro SEW Accel system provides vibration monitoring suited for the high electric fields of hydro generators by being designed to resist electrical tracking, corona damage, partial discharge, magnetic field interference and electric field interference. The 330447 SEW Accelerometer probe is mounted to the ground wall system using epoxy and glass roving.

The hydro SEW Accel system is designed to interface to the Bently Nevada 3500 monitoring system using the 46M Hydro monitor. The 3500/46M Hydro monitor has been enhanced to provide Stator End Winding measurements and displays. A key feature is the measurement of the Pole Passing Frequency (or Forcing Frequency) amplitudes. Additionally, the 3500/46M will display the resultant acceleration measurements for the combined X and Y-axis to provide a complete vibration overview.

Monitoring of hydro stator end windings can prevent catastrophic failure and help determine proper maintenance cycles if used properly. Defects caused by prolonged exposure to electrical tracking and ozone will wear down stator end winding insulation, which can lead to increased vibration. The hydro SEW Accel system can monitor the vibration of select stator end windings in a hydro generator. This data can be trended to aid in determining the integrity of the hydro generator insulation as it ages.

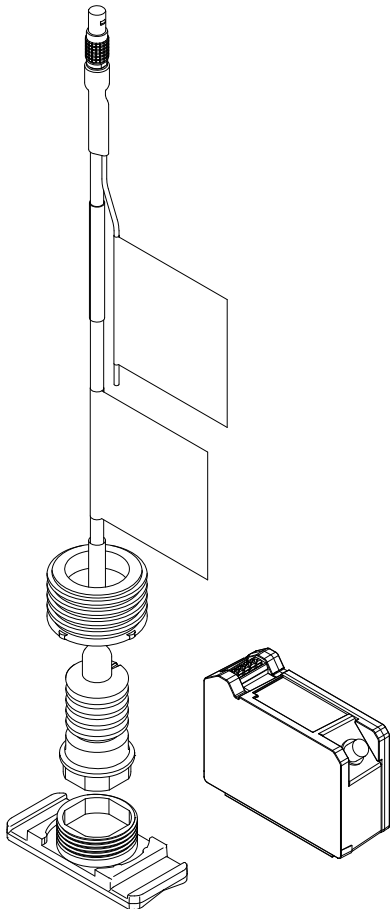

Specifications

Unless otherwise noted, the following specifications apply to the hydro SEW Accel system which is a combination of the 330447 Accelerometer probe and the 330446 Accelerometer Sensor.

Parameters are specified from +20 to +30 °C (+68 to +86 °F), 100 Hz, and with a 10 kΩ load unless otherwise indicated.

Electrical

Sensitivity:

10.19 mV/m/s² (100 mV/g) ±5%
10.19 mV/m/s² (100 mV/g)
±10% 5°F to +167°F [-15°C to +75°C]

Note: Accuracy calculated with 95% confidence factor. Please refer to the Product Installation Manual for proper mounting instructions.

Frequency Response:

DC to 360 Hz, -3 dB, minimum
DC to 400 Hz, -3 dB, typical
DC to 440 Hz, -3 dB, maximum

DC to 130 Hz; -10%, minimum
DC to 195 Hz, -10%, typical
DC to 245 Hz; -10%, maximum

Typical Measured Acceleration:

±1.5% at 100 Hz at 1 g

Acceleration Range:

±343 m/s² pk (±35 g pk)

Nonlinearity:

±2% to ±343 m/s² pk (±35 g pk)

Transverse Sensitivity:

< 5mV/g for vibration applied in the orthogonal plane from the sensitive axis

Resonant Frequency:

Greater than 1 kHz

Power Consumption:

24 ma or 0.58 W Maximum

Electrical Insulation:

48 kVac of dielectric strength

Output:

Single ended
-11.6 Vdc bias voltage ±5%
±3.5 Volts dynamic range

Broadband Noise Floor:

0.0082 m/s² pk (0.08 g pk) Typical

CE Mark Directive

Radiated Emissions:

EN61000-6-4 (2007), Criteria A

Electrostatic Discharge:

EN61000-4-2 (1995 w/A1: 98 & A2: 01)
EN61000-6-2 (2005), Criteria B

Radiated Susceptibility:

EN61000-4-3 (2002 w/A1: 02)
EN61000-6-2 (2005), Criteria A

Electrical Fast Transients:

EN61000-4-4 (1995 w/A1 & A2: 01)
EN61000-6-2 (2005), Criteria B

Surge Capability:

EN61000-4-5 (1995 w/A1: 01)
EN61000-6-2 (2005), Criteria B

**Conducted
Susceptibility:**

EN61000-4-5 (1996 w/A1: 01)
EN61000-6-2 (2005), Criteria B

Environmental

Note: Operation outside the specified limits may result in false readings or loss of machine monitoring.

**Temperature
Ranges:**

**330446
Accelerometer
Sensor**

Operating:
5°F to +167°F [-15°C to +75°C]
Storage:
-40°F to +185°F [-40°C to +85°C]

**330447
Accelerometer
Probe**

Operating:
5°F to +203°F [-15°C to +95°C]
Storage:
-40°F to +203°F [-40°C to +95°C]

**System Relative
Humidity
Performance**

Less than 5% deviation in the transducer sensitivity when tested in 93% humidity in accordance with IEC standard 68-2-3 for up to 56 days.

Physical

Field Wire

305 m [1000 ft] maximum with 80 nF maximum (between one conductor and drain wire, with all other conductors connected to drain wire)

Note: See recommended field wire in Accessories. Using field wire not similar to the recommended field wire may result in false readings or loss of machine monitoring.

Component Materials

**330447 Housing,
Threaded Cap
and Mounting
Base**

Polytron E102

**330447 Integral
Cable Outer
Jacket**

Santoprene

**330447
Grounding Strap
Outer Jacket**

PVC

330446 Housing

A380 Aluminum

Component Weights:

**330446
Accelerometer
Sensor**

0.5 lbf [2.4 N]

**330447 6-Meter
Assembly**

0.8 lbf [3.6 N]

**330447 10-Meter
Assembly**

1.2 lbf [5.4 N]

**330447
Accelerometer
Probe, Cap and
Mounting Base**

0.2 lbf [1 N]

Mechanical

**Kinetic Impact
Resistance
(330447 Package)**

Up to 5.5 Joules

**Integral Cable
Pull Axial
Strength (At
330446 SEW
Accelerometer
Probe)**

60 lbf [267 N]

**Integral Cable
Bend Radius**

1 inch [25.4 mm]

**Threaded Cap
Torque**

4-6 lb-ft [5-8 N-m]

Ordering Information

330446 SEW Accelerometer Sensor

330446 – AXX – BXX – CXX

A: Sensor Type
01 Standard SEW Accelerometer
 Sensor (Default)

B: Mounting Option
00 No Mounting Hardware

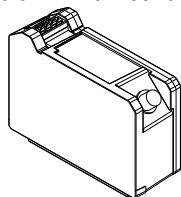

01 Panel Mount Hardware

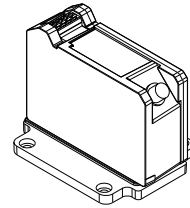

02 Din Mount Hardware

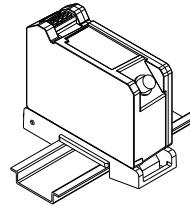

C: Approvals

00 None (Default)

**330447 SEW Accelerometer Probe
330447-AXX-BXX**

A: Cable Length
06 6-Meters [19.7ft] ± 0.15 [0.5]
10 10-Meters [32.8ft] ± 0.15 [0.5]

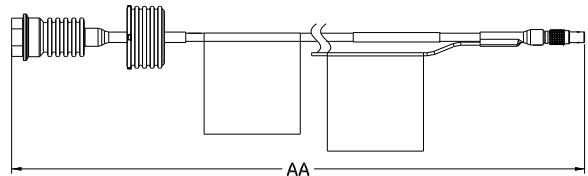

B: Approvals
00 No Approvals

Note: The 330447 includes one *mounting base* and one *threaded cap* per order. If extras are needed, they can be ordered as spares.

Mounting Epoxy and Glass Roving

Important: Proper mounting of the 330447 SEW Accelerometer Probe requires the use of epoxy and glass roving material. Additionally, both are required to validate the warranty policy. Depending on the specific ground wall material, the type of epoxy and glass roving resin may vary from machine to machine. Plant personnel should qualify their own selection. For convenience, Bently Nevada has identified the following vendor and materials:

Vendor Information:

Company: Astro Chemical Company

Website: www.astrochemical.com

Recommended Vendor Products:

Mounting Base Epoxy:

P/N Barco Bond MB100X Kit

Glass Roving:

P/N Astro 7000R

Glass Roving Resin:

P/N Astro 6021 Quart Kit

Accessories

Note: Some accessories may have options. Please contact Bently Nevada for assistance in ordering.

181789-01	Product Installation Manual
175751	3300 XL Multi-Purpose HSG 12"X12"X6" SST
176467	3300 XL Multi-Purpose Hsg 12"X8"X6" SST
181429-01	Spare, SEW Accel Threaded Cap
181430-01	Spare, SEW Accel Mounting Base
167276	RTV for Locking Threaded Cap
148168	Recommended SEW Field Wire

Safety

Proper installation is required to avoid hazardous conditions. Please refer to the Product Installation Manual, before installing the hydro SEW Accel system. A multi purpose housing (175751/176467) should be used to enclose the 330446 Accelerometer Sensor in the rare case that a grounding fault should occur. Plant personnel should pay close attention to the following:

- Mounting Location
- Mounting Procedure
- Cable Routing
- Earth Grounding

Graphs and Dimensional Drawings

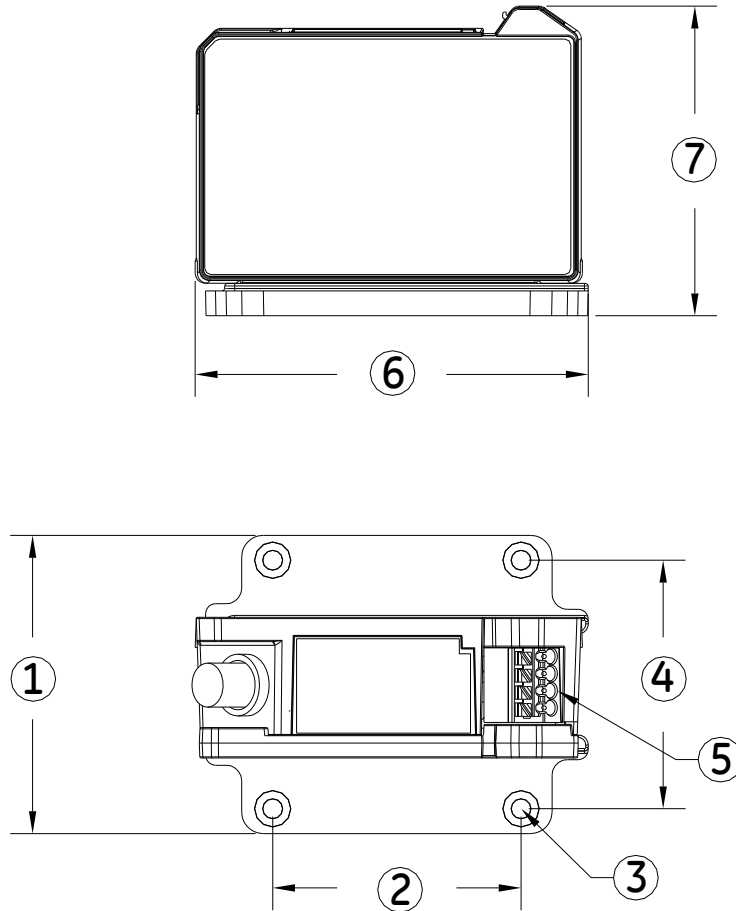

1. 2.4 [61.0] MAX
2. 2.0 [50.8]
3. 4X C'BORE ϕ .290 [7.37] x .105 [2.67] DEEP. ϕ .158 [4.01] THROUGH
4. 2.0 [50.8]
5. Field Wire Terminal Block Accepts Wire Sizes 16-24 AWG [0.2-1.5 sq. mm]
6. 3.2 [80.4] MAX
7. 2.5 [63.3] MAX

Figure 1: 330446 Accelerometer Sensor Panel Mount Dimensions

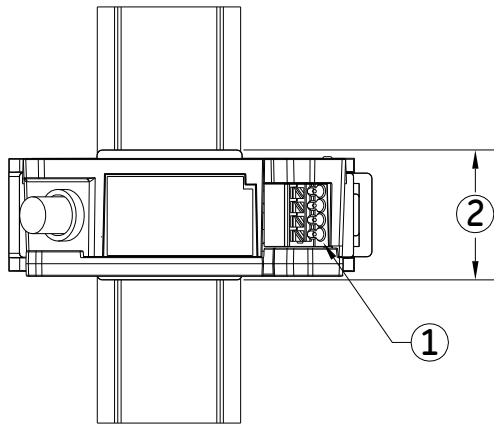
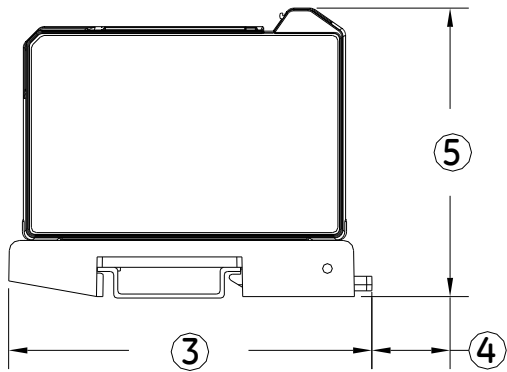

1. Field Wire Terminal Block Accepts Wire Sizes 16-24 AWG [0.2-1.5 sq. mm]
2. 1.2 [31.7] MAX
3. 3.5 [88.7] MAX
4. .12 [3.05] MINIMUM CLEARANCE REQUIRED FOR MOVEMENT OF DIN CLIP TO ALLOW REMOVAL OF 330446 ACCELEROMETER SENSOR FROM 35mm DIN RAIL
5. 2.8 [70.4] MAX

Figure 2: 330446 Accelerometer Sensor DIN Mount Dimensions

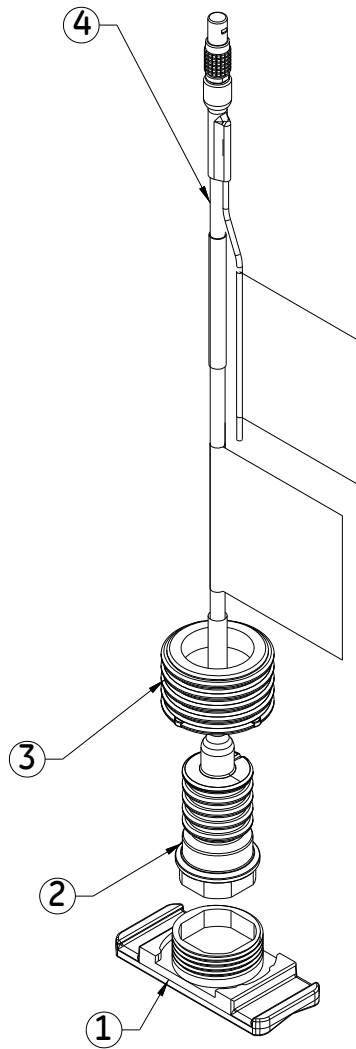

1. SEW Accel Mounting Base (P/N 181430-01)
2. SEW Accelerometer
3. SEW Accel Threaded Cap (P/N 181429-01)
4. SEW Accelerometer Integral Cable

Figure 3: 330447 Accelerometer Bill of Materials

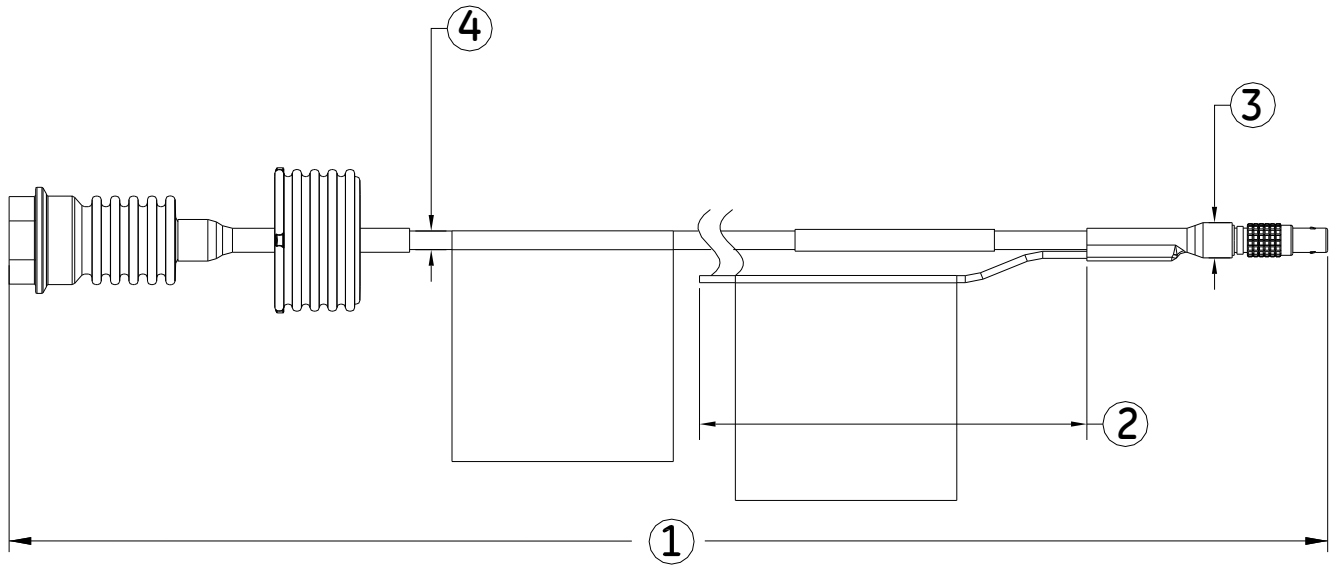

1. Cable Length Ordering Option (See Ordering Option For Dimensions).
2. Ground Strap Length is 24 in [609.6 mm] ± 2.0 in [50 mm]
3. Maximum Diameter with Heat Shrink over connector is .4 inches [10.2]
4. Maximum Outer Cable Diameter is 0.22 inches [5.6]

Figure 4: 330447 Accelerometer Cable Dimensions

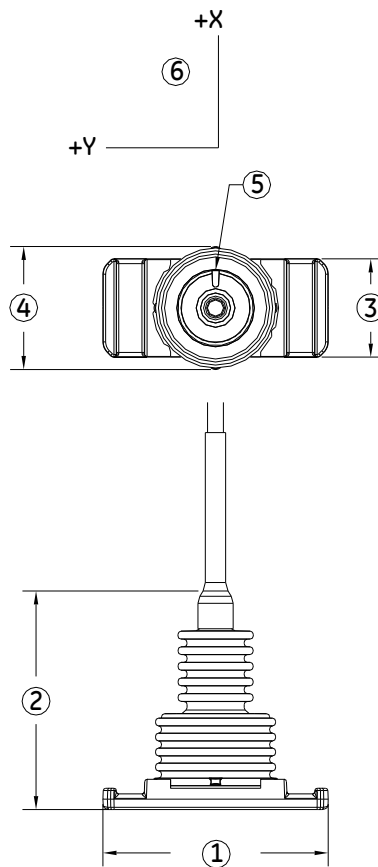

1. Max 3.01 [76.5]
2. Max 2.88 [73.2]
3. Max 1.32 [33.5]
4. Max 1.65 [41.9]
5. Notch on Top of 330447 Accelerometer Probe Housing Corresponds to +X Axis of accelerometer
6. +Y Axis of accelerometer is 90 degrees counterclockwise from +X Axis when displayed as shown in this figure

Figure 5: 330447 Accelerometer Probe Overall Dimensions and Sensitive Axes

SEW Accel Freq Response

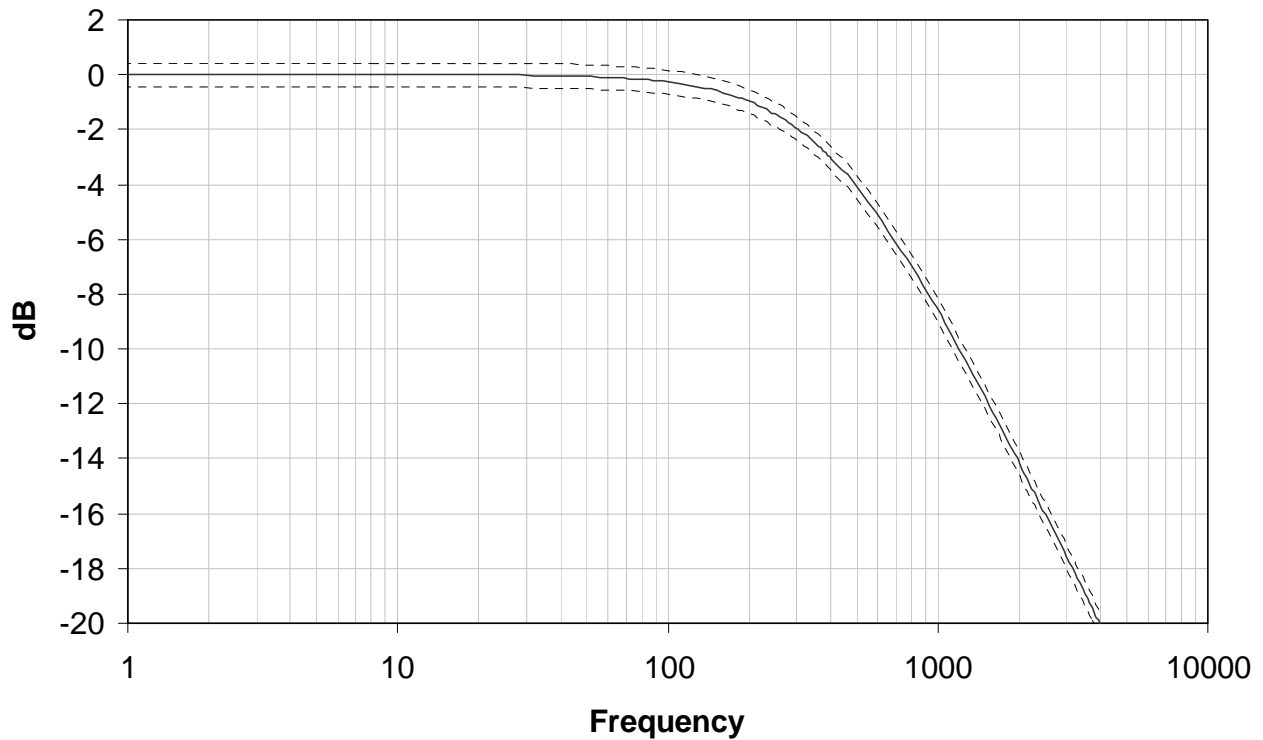

Figure 6: Typical 330447 frequency response with upper and lower limits shown

Dimensions shown in inches [mm] except as noted

Bently Nevada is a trademark of General Electric Company.
Polytron is a trademark of Industrial Dielectrics, Inc.
Santoprene is a trademark of the Exxon Mobil Corporation.

Copyright 2008. Bently Nevada LLC.
1631 Bently Parkway South, Minden, Nevada USA 89423
Phone: 775.782.3611 Fax: 775.215.2873

www.ge-energy.com/bently

All rights reserved.